

# Installation Hardware

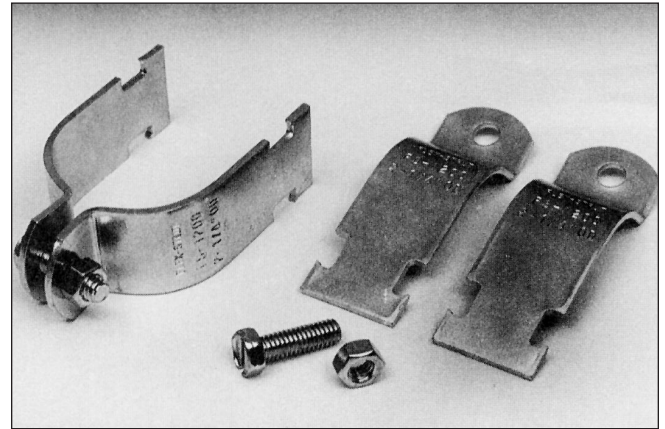

## Strut, Strut Clamps and Accessories

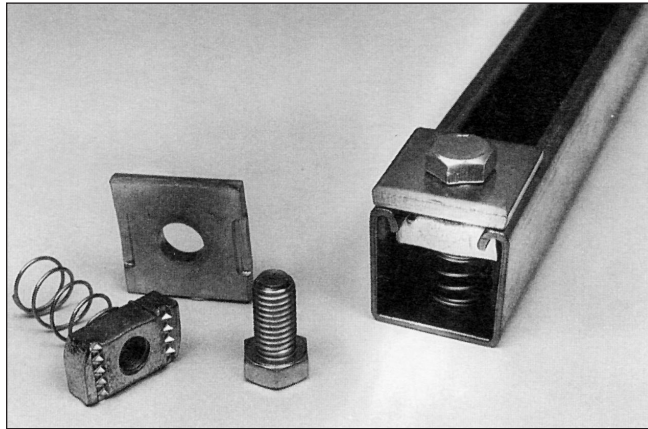

### Strut Channel

Size	A	B	Gauge	Wt./Ft.
200	1-5/8"	1-5/8"	12	1.88
300	1-5/8"	1-3/8"	12	1.70
400	1-5/8"	1"	12	1.43

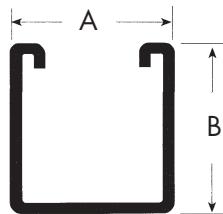

Other sizes upon request.

Available: Plain, with Slots, Short Slots or Holes.

Finishes: Plain, Pre-Galvanized and Green.

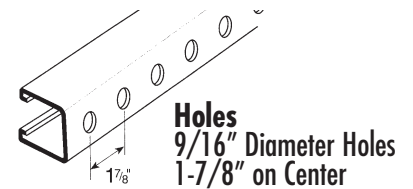
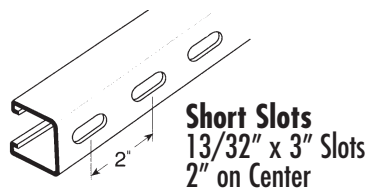
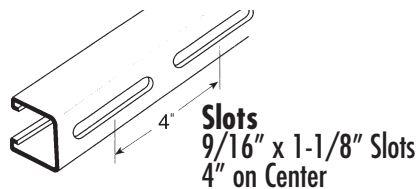

### Channel Nuts

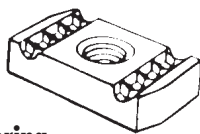

#### No Spring

Size	Thread	Thickness	Wt.Lbs./C
#8	32	1/4"	6.5
#10	32	1/4"	6.5
#10	24	1/4"	6.5
1/4"	20	1/4"	6.5
5/16"	18	3/8"	8.7
3/8"	16	3/8"	9.0
1/2"	13	1/2"	10.6
5/8"	11	7/16"	14.0
3/4"	10	7/16"	14.0
1/2"	13	3/8"	8.5
5/8"	11	3/8"	14.0

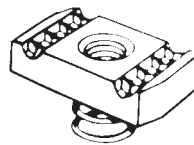

#### Short Spring Size 400 Channel

Size	Thread	Thickness	Wt.Lbs./C
#8	32	1/4"	7.5
#10	32	1/4"	7.5
#10	24	1/4"	7.5
1/4"	20	1/4"	7.5
5/16"	18	3/8"	8.7
3/8"	16	3/8"	9.0
1/2"	13	3/8"	8.2
5/8"	11	3/8"	14.0

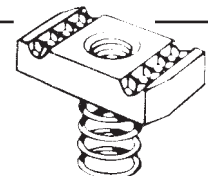

#### Regular Spring Size 200,300 Channel

Size	Thread	Thickness	Wt.Lbs./C
#8	32	1/4"	7.5
#10	32	1/4"	7.5
#10	24	1/4"	7.5
1/4"	20	1/4"	7.5
5/16"	18	3/8"	9.7
3/8"	16	3/8"	10.0
1/2"	13	1/2"	11.5
5/8"	11	7/16"	15.0
3/4"	10	7/16"	15.0
7/8"	9	7/16"	15.0

# Installation Hardware (continued)



## All-Thread



Diameter Size	Thread	Wt. Lbs./C
1/4"	20	12
3/8"	16	30
1/2"	13	52
5/8"	11	85
3/4"	10	123

Length = 6', 10', or 12'  
Finish = Electro-Galvanized

## Rod Couplers

Hole Size	Thread	A	Wt. Lbs./C
1/4"	20	7/8"	2
5/16"	18	7/8"	2
3/8"	16	1-3/4"	11
1/2"	13	1-3/4"	11
5/8"	11	2-1/8"	16
3/4"	10	2-1/4"	28

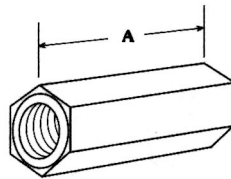

## Beam Clamps

A	B	C	#/Cpc	Allowable Load
1/4"-20	1/8"	3/8" x 2"	105	800#
3/8"-16	3/16"	1/2" x 2"	160	1300#
1/2"-13	1/4"	1/2" x 2"	200	1900#

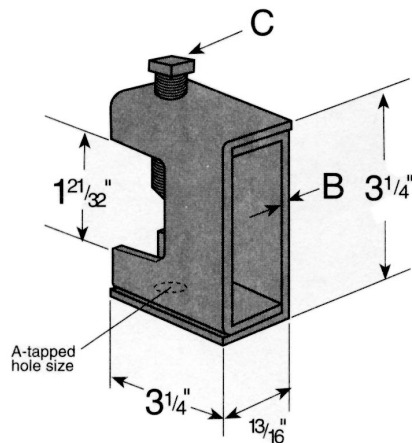

## Pipe Clamps

FS-1200 Series  
O.D. Tubing Clamps

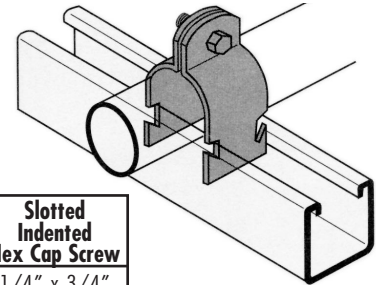

O.D. Tube Size	#/Cpc	Load	Slotted Indented Hex Cap Screw
1/4"	8#	400#	1/4" x 3/4"
3/8"	8#	400#	1/4" x 3/4"
1/2"	9#	400#	1/4" x 3/4"
5/8"	10#	400#	1/4" x 3/4"
3/4"	11#	400#	1/4" x 3/4"
7/8"	12#	400#	1/4" x 3/4"
1"	14#	600#	1/4" x 3/4"
1-1/8"	15#	600#	1/4" x 3/4"
1-1/4"	16#	600#	1/4" x 3/4"
1-3/8"	17#	600#	1/4" x 3/4"
1-1/2"	18#	600#	1/4" x 3/4"
1-5/8"	19#	600#	1/4" x 3/4"
1-3/4"	29#	800#	5/16" x 1"
1-7/8"	28#	800#	5/16" x 1"
2"	31#	800#	5/16" x 1"
2-1/8"	32#	800#	5/16" x 1"
2-1/4"	33#	800#	5/16" x 1"
2-3/8"	34#	800#	5/16" x 1"
2-1/2"	35#	800#	5/16" x 1"
2-5/8"	37#	800#	5/16" x 1"
2-3/4"	38#	800#	5/16" x 1"
2-7/8"	40#	800#	5/16" x 1"
3"	41#	800#	5/16" x 1"
3-1/8"	43#	800#	5/16" x 1"
3-1/4"	45#	800#	5/16" x 1"
3-3/8"	46#	800#	5/16" x 1"
3-1/2"	47#	800#	5/16" x 1"
3-5/8"	56#	1000#	3/8" x 1-1/4"
3-3/4"	58#	1000#	3/8" x 1-1/4"
3-7/8"	60#	1000#	3/8" x 1-1/4"
4"	62#	1000#	3/8" x 1-1/4"
4-1/8"	62#	1000#	3/8" x 1-1/4"
4-1/4"	64#	1000#	3/8" x 1-1/4"
4-3/8"	66#	1000#	3/8" x 1-1/4"
4-1/2"	67#	1000#	3/8" x 1-1/4"
4-5/8"	70#	1000#	3/8" x 1-1/4"
4-3/4"	72#	1000#	3/8" x 1-1/4"
4-7/8"	73#	1000#	3/8" x 1-1/4"
5"	74#	1000#	3/8" x 1-1/4"
5-1/8"	76#	1000#	3/8" x 1-1/4"
5-1/4"	77#	1000#	3/8" x 1-1/4"
5-3/8"	78#	1000#	3/8" x 1-1/4"
5-1/2"	79#	1000#	3/8" x 1-1/4"
5-5/8"	88#	1000#	3/8" x 1-1/4"
5-3/4"	90#	1000#	3/8" x 1-1/4"
5-7/8"	92#	1000#	3/8" x 1-1/4"
6"	92#	1000#	3/8" x 1-1/4"