

Pressure Blowers



Pressure blower packages are sized to match your requirements. Standard packages range from 2" to 6" systems with flows up to 2,370 CFM, pressures to 15 PSIG. Each blower package consists of the blower, v-belt drive, OSHA guard, TEFC drive motor, adjustable motor slide base and inlet filter all mounted on top of a heavy duty, unitized base/discharge silencer in one compact, easy to install package. Options include inlet silencers, check valves and control sensors.

- Factory engineered, factory guaranteed
- Compact package designed for ease of handling and installation
- Indoor or outdoor operation

Optional Equipment:

- Temperature Switches
- Pressure Switches
- Pressure Transmitters
- Inlet Silencer

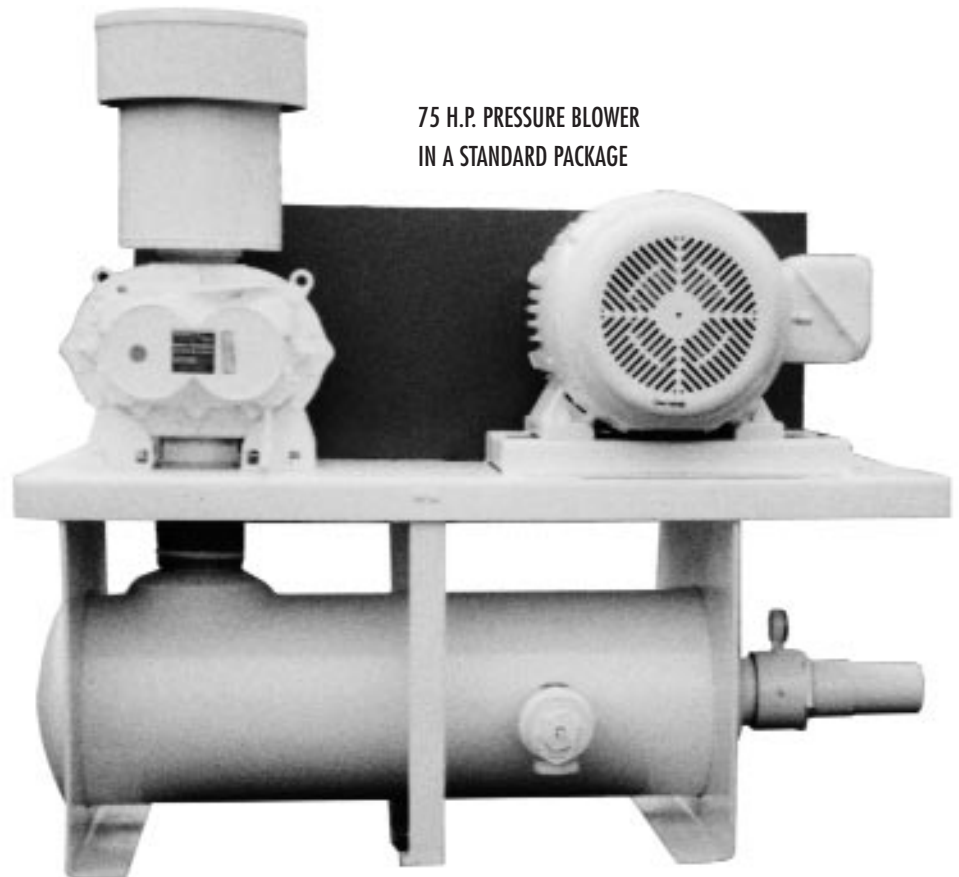

75 H.P. PRESSURE BLOWER
IN A STANDARD PACKAGE

Pressure Blowers (continued)



STANDARD PACKAGE

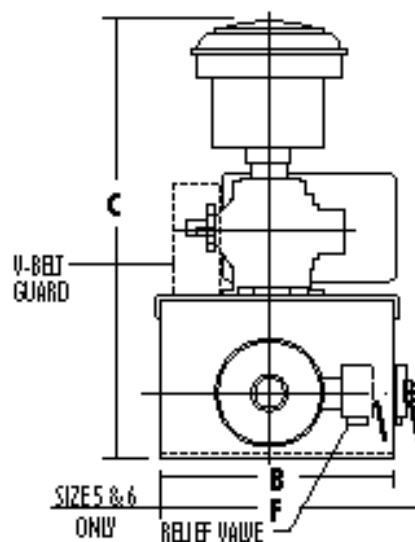
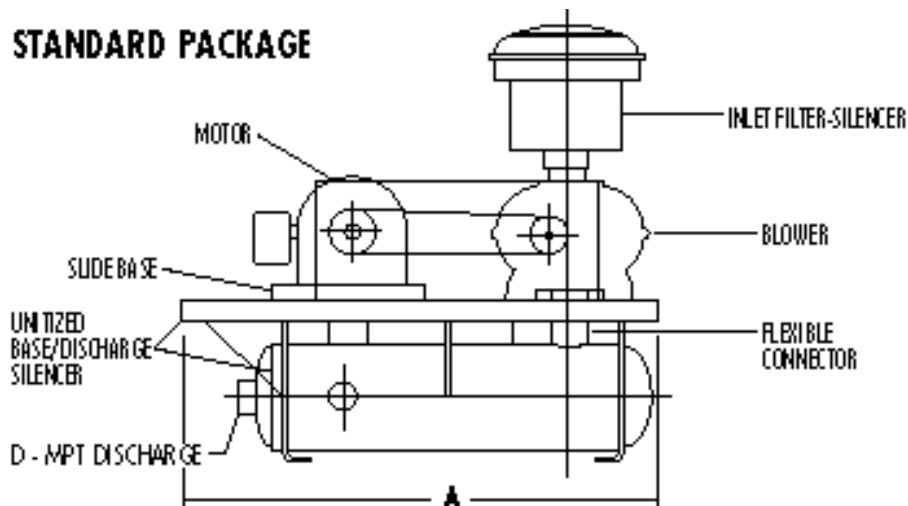

PACKAGE WITH INLET SILENCER

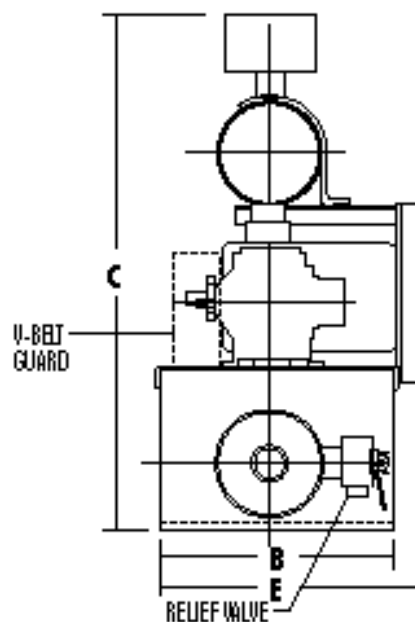
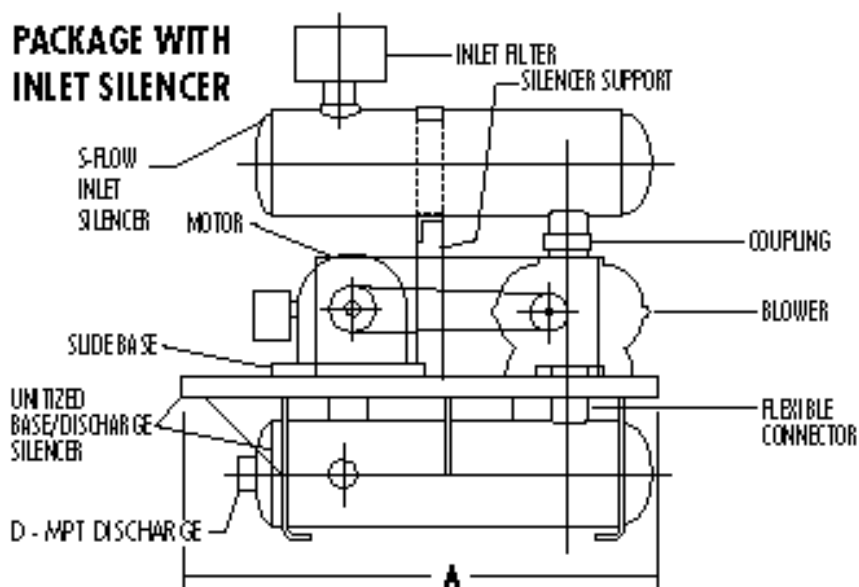

NOTES:

1. All dimensions are in inches.
2. Dimensions are approximate - do not use for construction. Packages may not be exactly as shown.
3. Dimension "C" and approximate weights are for largest blower frame size used.
4. Approximate weights do not include motor.

Discharge Pipe Size	Blower Frame Sizes	A	B	C (Maximum)		D	E	F	Approx. Net Weight (Maximum)	
				w/Silencer	Standard				w/Silencer	Standard
2	22, 24, 32, 33, 42	39.00	23.00	48.00	36.38	2	25.18	-	325	295
2-1/2	36, 45, 53	44.50	27.00	58.13	57.13	2-1/2	29.18	-	510	400
3	45, 47, 56, 65	51.50	29.25	68.13	56.38	3	32.50	-	835	725
4	47, 56, 59, 68, 76	56.00	32.50	82.06	64.50	4	35.75	-	1174	1037
5	59, 68, 711	66.00	34.50	82.75	71.38	5	37.75	35.50	1501	1280
6	615, 711, 718	68.50	34.50	99.13	98.00	6	37.75	37.62	1837	1495