

# Silo Maintenance Gates



Silo maintenance gates provide a positive shut-off of material below silos or surge bins. Advanced Bulk and Conveying, Inc., valves are available for powder or pellet applications.

## Powder Valve

Constructed of aluminum channel, these valves are the best choice for handling fine materials and powders. The 304 stainless steel blade, manual hand crank actuator and nylon seals make for a quality valve designed for fine powders in a dilute phase application.

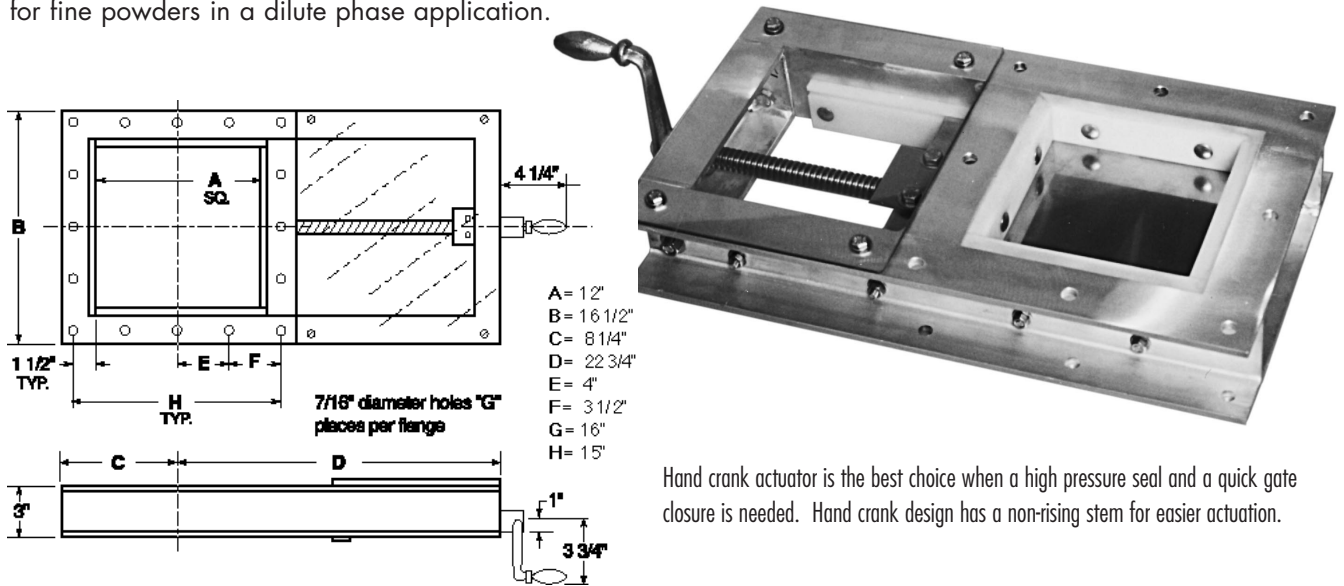

## Pellet Valve

When working with pellet material, our economical pellet silo maintenance valve uses the same aluminum channel construction but does not have the tight tolerances required for handling fine powders. Valve comes with all aluminum product contact surfaces and hand crank actuator.

