

Self-Cleaning Central Filter



Advanced Bulk and Conveying, Inc., self-cleaning central filters are free-standing vacuum filters which use reverse pulse compressed air to automatically clean the filter media. These filters save on maintenance time and filter replacement costs when compared with standard cartridge type vacuum filters. The unit is constructed of carbon steel, comes with industrial enamel finish, 6" butterfly valve dust discharge, polyester felt filter bags, bottom bag removal with side door filter access, 110 VAC reverse pulse blow down panel and outlet check valve.

Options:

- Choice of Filter Media
- Pressure Differential Gauge
- Pleated Cartridge Filters Available for Increased Air-to-Cloth Ratio
- High Dust Level Sensor
- Available in 4, 5 or 7 Bag Configuration

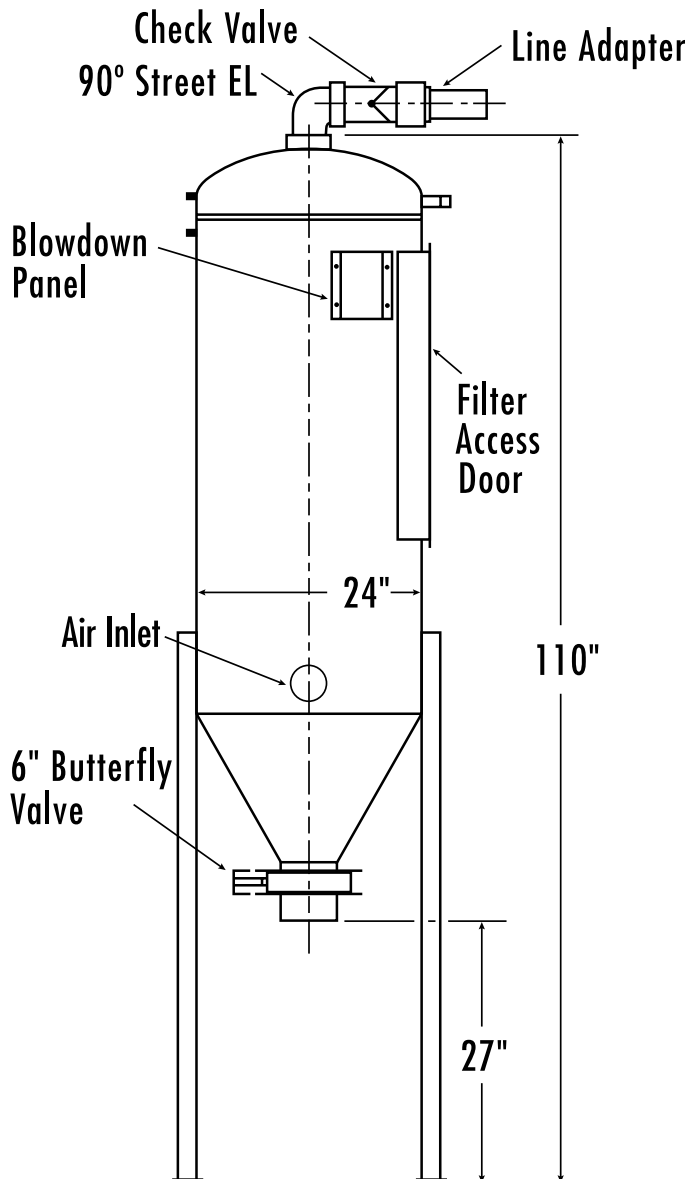

Self-Cleaning Central Filter shown with optional automatic dump flapper valve.