

# Vacuum Loaders



Advanced Bulk and Conveying, Inc., vacuum loader packages come completely assembled, engineered and factory guaranteed. Our standard package includes a Roots Universal RAI rotary positive displacement blower, v-belt drive, OSHA guard, TEFC motor with slide base, relief valve, vacuum gauge and discharge silencer all mounted on a unitized base.

- Factory Engineered, Factory Guaranteed
- Compact Package Designed for Ease of Handling and Installation
- Indoor or Outdoor Operation

**Optional Equipment:**

- Air Actuated Vacuum Breaker Valve
- Self-Cleaning Central Filter
- Temperature Switches
- Vacuum Switches
- Vacuum Transmitters
- Inlet Silencer

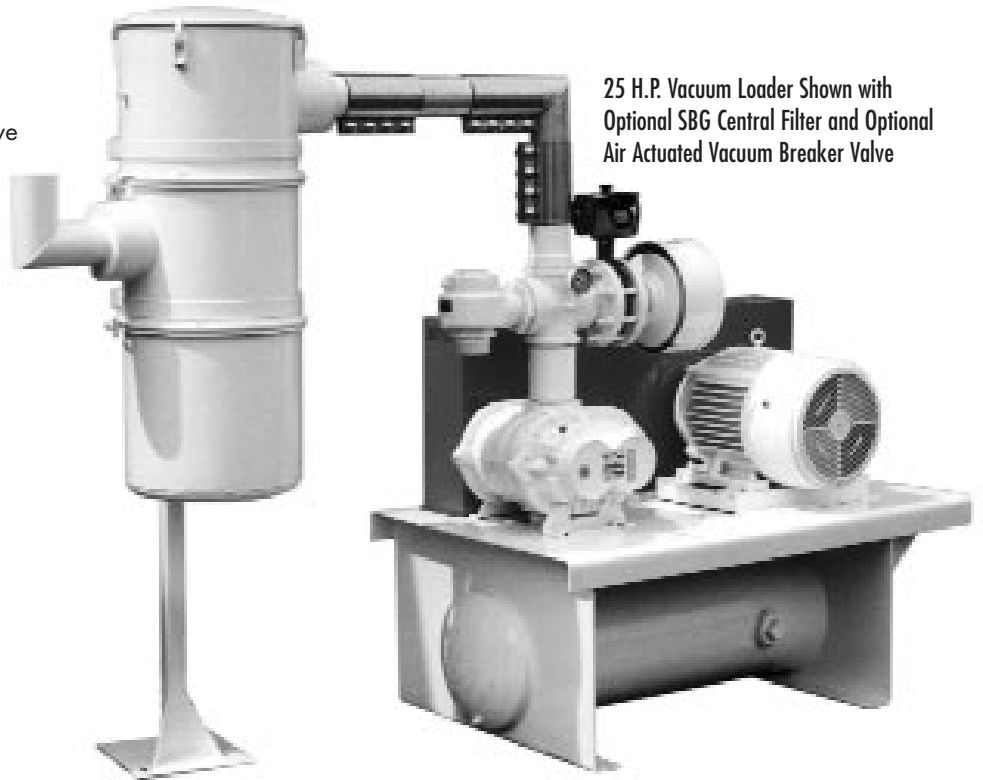

25 H.P. Vacuum Loader Shown with Optional SBG Central Filter and Optional Air Actuated Vacuum Breaker Valve

**STANDARD VACUUM LOADERS**

Model	Motor	Pump Size	Line Size
533VL	5HP	33URAI	2"
1045VL	10HP	45URAI	2.5"
1556VL	15HP	56URAI	3"
2568VL	25HP	68URAI	4"
40 VL	40HP		4"
60 VL	60HP		6"

# Vacuum Loaders (continued)

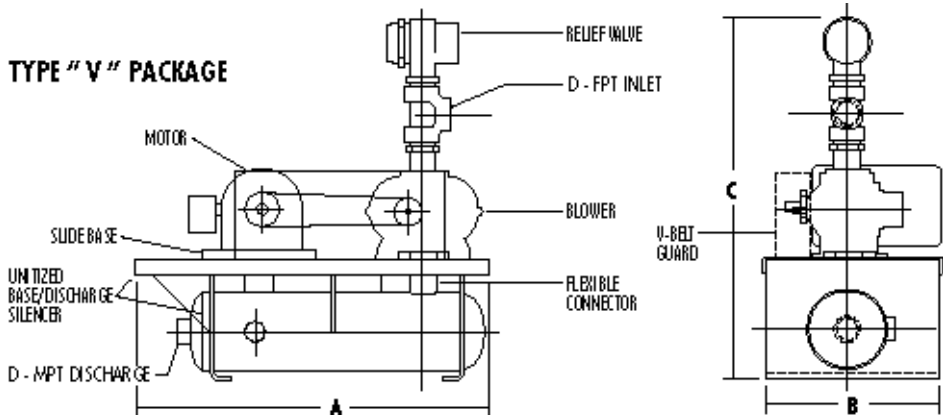

**NOTES:**

1. All dimensions are in inches.
2. Dimensions are approximate - do not use for construction. Packages may not be exactly as shown.
3. Dimension "C" and approximate weights are for largest blower frame size used.
4. Approximate weights do not include motor.

Discharge Pipe Size	Blower Frame Sizes	A	B	C (Max) TYPE "V"	D	E	F	Approx. Net Weight (Maximum)
2	22, 24, 32, 33, 42	39.00	23.00	37.75	2	25.18	-	290
2-1/2	36, 45, 53	44.50	27.00	43.25	2-1/2	29.18	-	415
3	45, 47, 56, 65	51.50	29.25	47.75	3	32.50	-	710
4	47, 56, 59, 68, 76	56.00	32.50	60.93	4	35.75	-	1012
5	59, 68, 711	66.00	34.50	69.50	5	37.75	35.50	1250
6	615, 711, 718	68.50	34.50	72.50	6	37.75	37.62	1330

To complete your vacuum loading system, Advanced Bulk and Conveying, Inc., has a full line of vacuum filters, receiving chambers and control panels.

